

Description

HBB Touch Switches are the friendly members of the system that can control the utilities with only one simple touch. In PRIME sub series the new touch hardware (GEN3.0) filter all noises which can affects your touch signal. Different Icons, Aluminum frame and RGB led indicators are the bold characteristics which added to PRIME series. Longer size of the switch is another character which caused better functions and visual attraction.

Features

- Capacitive touch buttons (GEN3.0)
- Auto calibration
- Broadcast detection
- Clean / test mode
- RGB LED indicators
- H-BUS compatible
- 3 Methods of standard wall mount installation
- DIY Button defining
- Aluminum frame

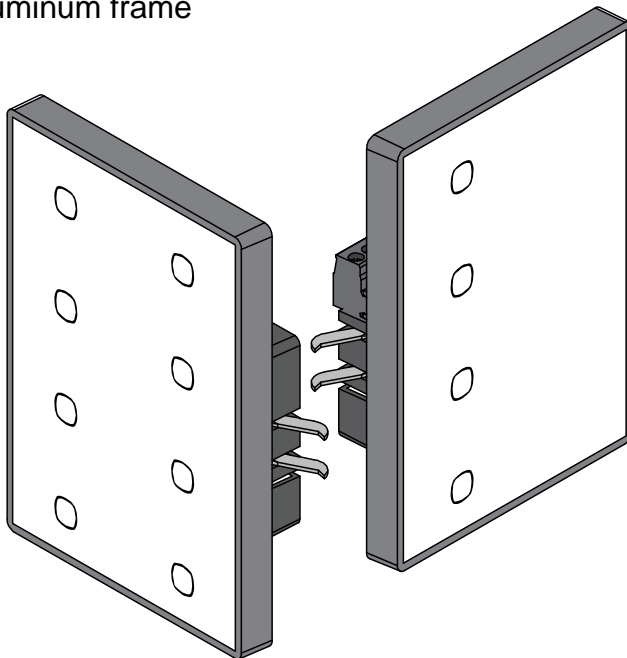

Specifications

- Operating voltage: 18 ~ 24.5 V DC
- Maximum operating current: 100 mA
- Normal operating current: 50 mA
- Button type: Capacitive touch buttons
- Indicators: RGB LEDs
- Communication: H-BUS
- Installation: Wall mount and wall clamps
- Weight: 50 g
- Size: W 90.6 x L 125.3 x H 14.6(40.7) (mm)

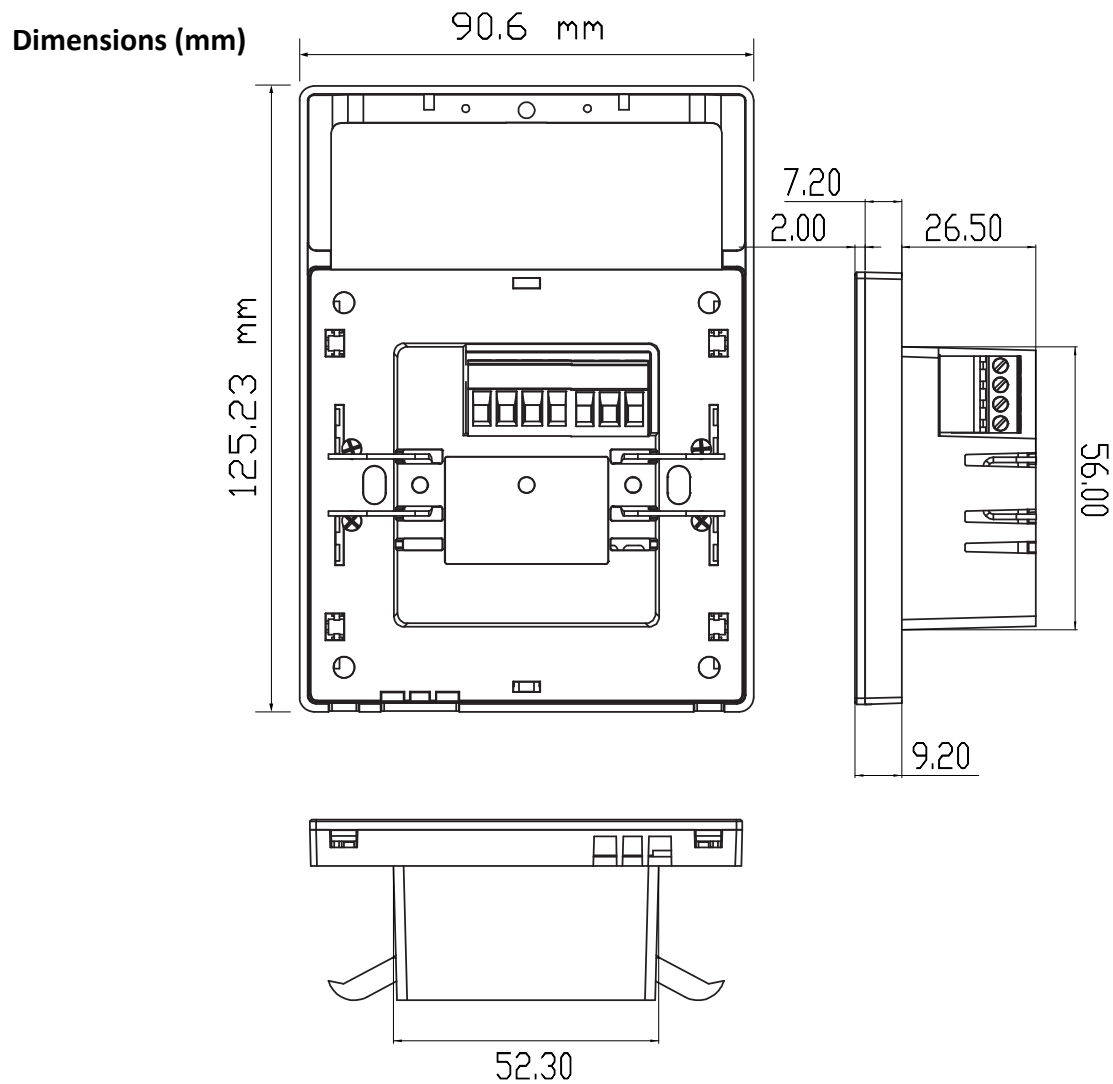

Electrical diagram

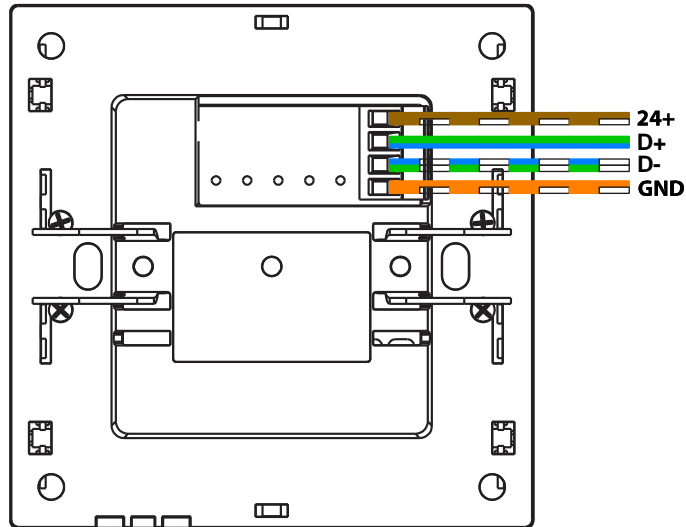

*****Caution: Data lines (D+ and D-) may differ in different models. Pay attention to the guide label behind the BUS Coupler.**

Communication

H.BUS GND		orange
H.BUS GND		w/orange
H.BUS D+		blue
H.BUS D-		w/blue
H.BUS D+		green
H.BUS D-		w/green
H.BUS +24V		brown
H.BUS +24V		w/brown

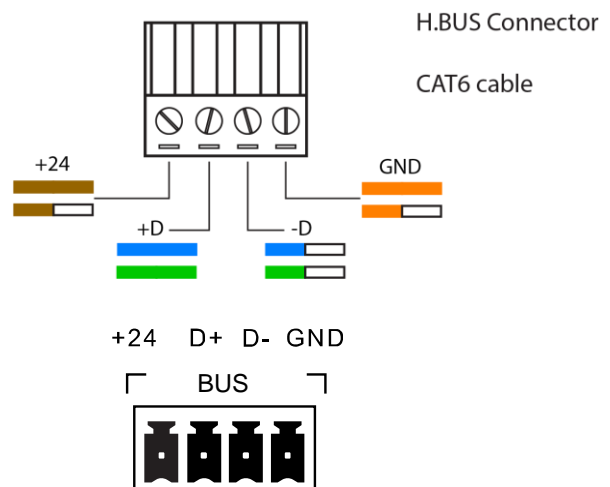

Physical Installation

